



**GE**  
Electric Dirtbike

Greenger Official Licensed Product.

Designed, manufactured and distributed by or for Greenger Electronic Technology LLC. Greenger, the Wing logo, and livery are licensed by American Greenger Motor Co., Inc.

Congratulations on choosing a GREENGER motorcycle.

The GREENGER is an ideal motorcycle for younger, beginning riders, which is child-only.

Before riding, take time to get acquainted with your motorcycle and how it works. To protect your investment, we urge you to take responsibility for keeping your motorcycle well maintained. Scheduled service is a must, of course.

This manual provides an overview of the proper maintenance and care required for motorcycles. By following these instructions diligently, you will ensure that your motorcycle runs smoothly without any issues for a long time.

If you have any questions, or if you ever need a special service or repairs, remember that your GREENGER dealer knows your motorcycle best and is dedicated to your complete satisfaction.

This manual should be considered a permanent part of the motorcycle and should remain with the motorcycle when resold or otherwise transferred to a new owner or operator.

This Owner's Manual contains the most up-to-date information at the time of printing. However, minor differences due to the further development of the design cannot be completely ruled out.

Wish you a happy riding!

All rights reserved:

This Owner's Manual cannot be copied or reproduced without written permission. The final interpretation of this user manual belongs to GREENGER ELECTRIC TECHNOLOGY LLC.

This Owner's Manual applies to the following model:

CRF-G2

Safety should be prioritized first. To help you make informed decisions about safety, we have provided operating procedures and other information on labels and in this manual. There are many *Safety Labels* on the motorcycle that you need to pay attention to.

Furthermore, you need to understand the meaning of the following signal words preceded by a safety alert symbol .

 **CAUTION**

Indicates a potential hazard that may result in minor or moderate injury.

 **WARNING**

Indicates a potential hazard that can result in death or serious injury.

 **DANGER**

Indicates a potential hazard that will result in death or serious injury.

|           |                                      |             |
|-----------|--------------------------------------|-------------|
| <b>1</b>  | <b>Motorcycle Safety .....</b>       | <b>p.1</b>  |
| <b>2</b>  | <b>Vehicle View .....</b>            | <b>p.14</b> |
| <b>3</b>  | <b>Vehicle Information .....</b>     | <b>p.17</b> |
| <b>4</b>  | <b>Operation Components .....</b>    | <b>p.20</b> |
| <b>5</b>  | <b>Combination Instrument .....</b>  | <b>p.24</b> |
| <b>6</b>  | <b>Basic Vehicle Operation.....</b>  | <b>p.36</b> |
| <b>7</b>  | <b>Maintenance Schedule .....</b>    | <b>p.44</b> |
| <b>8</b>  | <b>Service Your Vehicle .....</b>    | <b>p.49</b> |
| <b>9</b>  | <b>Brake System .....</b>            | <b>p.66</b> |
| <b>10</b> | <b>Motor, Battery, Charger .....</b> | <b>p.70</b> |
| <b>11</b> | <b>Cleaning and Storage.....</b>     | <b>p.80</b> |

# Motorcycle Safety

|   |             |
|---|-------------|
| <b>1.1 Important Safety Message.....</b>        | <b>p.2</b>  |
| <b>1.2 Notices to Parents.....</b>              | <b>p.5</b>  |
| <b>1.3 About First-time Using.....</b>          | <b>p.7</b>  |
| <b>1.4 Accessories &amp; Modifications.....</b> | <b>p.9</b>  |
| <b>1.5 Standardized Use of Batteries.....</b>   | <b>p.10</b> |
| <b>1.6 Intimate Service.....</b>                | <b>p.12</b> |
| <b>1.7 Environmental Protection.....</b>        | <b>p.12</b> |

## 1.1 Important Safety Message

We hope your child enjoy riding safely. And you must know, this motorcycle is designed and manufactured for off-road use only. To ensure that you and your child can have a wonderful time with this motorcycle, please take a few moments to read the following information before riding:

- 1. Ride Off-road Only.** Do not attempt to drive it on public roads, as doing so violates local traffic laws and presents several safety risks.
- 2. Control the speed.** When riding, adjust the speed reasonably according to the terrain to ensure you can react to potential hazards in time.
- 3. Choose Good Weather for Cycling.** Due to the complexity of off-road roads, it is advisable to ride in good weather conditions, as this reduces the likelihood of danger.

4. Equip with protective clothing. Make sure your child is wearing appropriate protective clothing, such as helmets, gloves, goggles, pants, boots, long-sleeved sweatshirts, shirts, or jackets, while riding. Always use protective equipment for your child that is in good condition and meets legal requirements. Here are some tips:

- **Helmet**

We recommend choosing helmets that meet national standards. The helmets should be brightly colored and in right sizes. Wearing an improper helmet may increase the possibility of severe injuries in an accident.

- **Gloves**

We recommend choosing highly abrasion-resistant full-finger leather gloves. You should also consider whether to wear insulated and slip-resistant cycling gloves based on the actual weather conditions.

- **Boots**

We recommend choosing comfortable and protective riding boots.

- **Clothing**

We recommend choosing a long-sleeved, protective shirt and durable pants (or a protective suit) for cycling.

**5.** Used by Child Only. Riding by adults is strictly forbidden. A passenger could interfere with the ability to maintain the balance and control of the motorcycle. Do not drink alcohol or any other alcoholic beverages before riding, as it will weaken your ability to react and avoid danger in time.

**6.** Before entering the off-road environment, make sure you have received necessary training and have the ability to cope with the off-road environment.

**Please always be vigilant!**

## 1.2 Notices to Parents

Children often misjudge or ignore potential hazards, so it is essential to keep an eye on them while they are riding to prevent any injuries. Here are some notices for you as parents.

**1.** Accurately assess your child's abilities and ensure that he has the skills and capabilities to ride the motorcycle. Please consider the following criteria:

- if your child is big enough that can put the vehicle upright independently after a fall.
- if your child has good balance and agility.
- if your child has a basic respect for cycling and avoid risky moves.
- if your child has the courage to face unexpected situations and calmly deal with them.

2. Your child must understand and follow the rules and instructions from you or another responsible person.
3. Do not ask too much of your child.
4. Do not consider participating in competitive activities until your child's stamina, riding skills, and motivation have reached the necessary levels.
5. Make it clear to your child that under no circumstances should he or she operate the vehicle without supervision.

**⚠ WARNING**    **Danger of burns**

Some motorcycle components become very hot when the vehicle is operated.

- Do not touch any parts such as the motor, battery, damper, or brake system before these motorcycle parts have cooled down.

- Let the motorcycle parts cool down before you perform any work on the vehicle.
- This motorcycle is a low-voltage (48V) electric motorcycle, so there may be a risk of heating around the motor after riding for a period of time. Please pay attention to the safety signs on the motorcycle. If the motorcycle experiences heating or even smoking, please stop using it immediately and turn off the power. Wait until the motorcycle has completely cooled down and ensure the parts are functioning properly before resuming your cycling. If you are not sure that your motorcycle can continue to operate normally, please contact the GREENGER dealer in time.

### 1.3 About First-time Using

The vehicle requires simple assembly before use. To avoid riding accidents after assembly, it should be assembled by an adult.

#### **Notice:**

Use provided lithium battery only when it is inside the vehicle.

It is important that you read this Owner's Manual carefully and completely before your child first rides this motorcycle.

The Owner's Manual contains useful information and many tips for you on how to handle, and service your motorcycle. It also provides information for your child on how to operate the motorcycle. This is the only way for you to find out how to tune the motorcycle ideally and how to protect your child from injury as possible.

Keep the Owner's Manual in an accessible place where you can refer to it quickly as needed.

If you would like to know more about the motorcycle or have questions on the material you read, please contact an authorized GREENGER dealer.

The Owner's Manual is an important component of this vehicle and must be handed over to the new owner if the vehicle is resold.

## 1.4 Accessories & Modifications

– No mechanical, electrical or electronic modification can be made to the motorcycle, as safe operation can not be guaranteed.

Examples of manipulation and modification that are **NOT ALLOWED**:

- (1) Opening the rechargeable lithium battery.
- (2) Using a damaged lithium battery.
- (3) Using the motorcycle or the rechargeable lithium-ion battery outside of its defined use .
- (4) Using the motorcycle or the rechargeable lithium-ion battery when proper maintenance has not been performed.

For the safety of your child, GREENGER recommends using our spare parts and accessories. GREENGER is not responsible for other products and for any damage or loss caused by them.

## 1.5 Standardized Use of Batteries



A rechargeable lithium battery ❶ is installed in the vehicle. The lithium battery supplies electric motor ❷ with voltage. The lithium battery is put into the frame and fixed.

If the power battery emits an odor, there may be a malfunction. Please immediately park your electric motorcycle in a safe outdoor location away from flammable materials, turn the power switch to the off position, and then contact your authorized dealer.

Please pay attention to the following matters after a collision:

(1) After a collision, you may be electrocuted if the e-motorcycle is severely damaged or deformed. Do not touch the 48V components or their wiring.

(2) Do not touch electrolyte solutions. If electrolyte solution splashes onto your eyes or skin, it may irritate your eyes and skin or cause burns. If you accidentally come into contact with the electrolyte, please rinse the affected area with plenty of water and seek medical attention immediately.

In the event of a fire, use a fire extinguisher suitable for electrical fires. It is quite a dangerous attempt to extinguish an electrical fire with a small amount of water. When extinguishing a fire with water in an emergency, be sure to use a fire hydrant or similar device that stores large amounts of water.

### **Notice:**

Please ride at a suitable temperature. If the temperature of the lithium battery is too high or too low, the motorcycle won't start and lead to dangerous situations.

## 1.6 Intimate Service

Since this motorcycle is exclusively designed for off-road riding, frequent exposure to sandy or muddy conditions may cause wear and tear on its components. Therefore, we kindly advise you to maintain your motorcycle regularly, and if needed, do not hesitate to contact an authorized dealer.

GREENGER' s authorized dealers are very willing to serve every user.

## 1.7 Environmental Protection

When you respect the rights of others and use your motorcycle legally, you will help protect the future of motorcycling and avoid most conflicts and problems.

When disposing of waste oil, auxiliary oil, and waste parts, please comply with the applicable laws and regulations of your country.

Your authorized GREENGER dealer can dispose of lithium battery in an environmentally friendly manner free of charge.

Electrical equipment such as battery must not be disposed of with household waste. Electrical equipment must be disposed of through an appropriate recycling center. Please contact your municipality or your authorized GREENGER dealer.

# Vehicle View

- 2.1 Vehicle view (Front right).....p.15**
- 2.2 Vehicle view (Front left).....p.16**

## 2.1 Vehicle view (Front right)

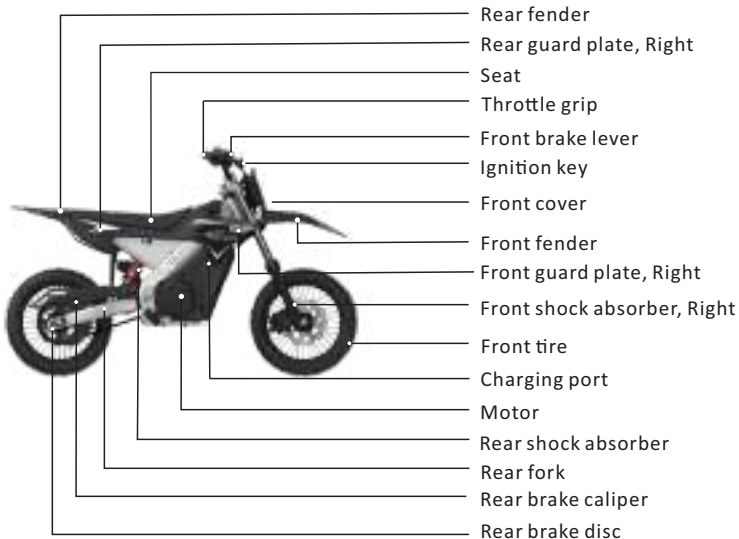



# Vehicle Information

|            |                               |             |
|------------|-------------------------------|-------------|
| <b>3.1</b> | <b>Vehicle VIN .....</b>      | <b>p.18</b> |
| <b>3.2</b> | <b>Vehicle nameplate.....</b> | <b>p.18</b> |
| <b>3.3</b> | <b>Battery parameter.....</b> | <b>p.19</b> |
| <b>3.4</b> | <b>Motor number.....</b>      | <b>p.19</b> |

### 3.1 Vehicle VIN



The vehicle VIN **1** is engraved on the right side of the steering head.

### 3.2 Vehicle nameplate



The vehicle nameplate **1** is located on the right side of the aluminum frame.

### 3.3 Battery parameter

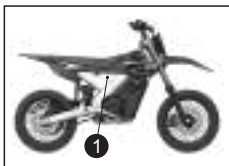

The battery parameter ① is engraved on the right side of the battery.

### 3.4 Motor number



The motor number ① is engraved on the rear side of the motor.

# Operation Components

|            |   |             |
|------------|---|-------------|
| <b>4.1</b> | <b>Rear hydraulic brake lever.....</b>  | <b>p.21</b> |
| <b>4.2</b> | <b>Front hydraulic brake lever.....</b> | <b>p.21</b> |
| <b>4.3</b> | <b>Throttle grip.....</b>               | <b>p.22</b> |
| <b>4.4</b> | <b>Ignition switch.....</b>             | <b>p.22</b> |
| <b>4.5</b> | <b>Start button.....</b>                | <b>p.23</b> |

### 4.1 Rear hydraulic brake lever



Rear hydraulic brake lever ① is located on the left side of the handlebar.

Use the rear hydraulic brake handle to perform the rear brake caliper brake action.

### 4.2 Front hydraulic brake lever



Rear hydraulic brake lever ① is located on the right side of the handlebar.

Use the rear hydraulic brake handle to perform the front brake caliper brake action.

### 4.3 Throttle grip



The throttle grip ① is located on the right side of the handlebar. Rotation of the throttle engages the motor and the amount of rotation is related to motor power.

### 4.4 Ignition switch



The ignition switch ① is located on front of the handlebar.

#### Possible states:

- Ignition off - In this position, the electric circuit of the battery is interrupted and the vehicle can not be activated.
- Ignition on - In this position, the electric circuit of the battery is opened and the vehicle can be started.

## 4.5 Start button

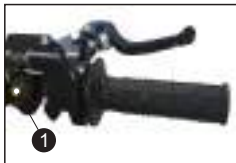

Start button **1** is fitted on the right side of the handlebar.

Start button is only enabled when the ignition is switched on.

When the start button is pressed, the vehicle switches from standby to riding mode.

### **Notice:**

Press the start button to switch the vehicle from standby mode to riding mode.

if the vehicle is not moved for 10 seconds, the vehicle automatically switches back to standby mode.



# Combination Instrument



|            |   |             |
|------------|---|-------------|
| <b>5.1</b> | <b>Combination instrument view.....</b> | <b>p.26</b> |
| <b>5.2</b> | <b>Function display .....</b>           | <b>p.27</b> |
| <b>5.3</b> | <b>Boot screen .....</b>                | <b>p.27</b> |
| <b>5.4</b> | <b>Instrument parameter.....</b>        | <b>p.28</b> |
| <b>5.5</b> | <b>Interface display.....</b>           | <b>p.29</b> |
| <b>5.6</b> | <b>Drive mode selection.....</b>        | <b>p.30</b> |
| <b>5.7</b> | <b>Error code display.....</b>          | <b>p.30</b> |

|             |   |             |
|-------------|---|-------------|
| <b>5.8</b>  | <b>Reset single mileage .....</b>       | <b>p.31</b> |
| <b>5.9</b>  | <b>Enter password setting .....</b>     | <b>p.32</b> |
| <b>5.10</b> | <b>Setting kilometers or miles.....</b> | <b>p.33</b> |
| <b>5.11</b> | <b>Power display.....</b>               | <b>p.34</b> |
| <b>5.12</b> | <b>Fault code definition.....</b>       | <b>p.35</b> |

### 5.1 Combination instrument view



There are three function keys on the instrument. On/Off key  in the front, Plus key  in the back, left side. Minus key  in the back, right side.

- Press the button  to control the on/off.
- Press the button  to control the different functions.
- Press the button  to control the different functions.
- Turning on ignition lock(p.22), the instrument automatically powers on.
- Turning off ignition lock(p.22), the instrument automatically powers off.

## 5.2 Function display

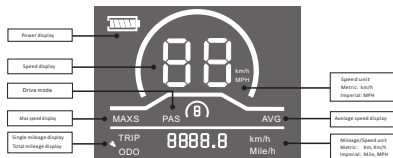

## 5.3 Boot screen



- Turn on ignition lock(p.22), the vehicle is activated that instrument display “OP” and enter standby mode.
- Press start button(p.23), instrument display “00”and vehicle enters riding mode.

### Notice:

If the vehicle is parked for more than 10 seconds, the vehicle will enter standby mode until the start button is pressed again.

### 5.4 Instrument parameter

|                          |               |
|--------------------------|---------------|
| Power                    | 48V           |
| Rated operation current  | 18mA          |
| Max. operation current   | 30mA          |
| Shutdown leakage current | < 1 $\mu$ A   |
| Output current           | 50mA          |
| Operating temperature    | -4°F ~ 140°F  |
| Storage temperature      | -22°F ~ 158°F |

## 5.5 Interface display

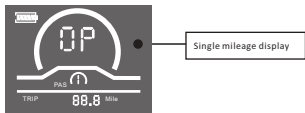

After the instrument is turned on, the instrument defaults to display real-time speed (mph) and single mileage (miles).

Repeatedly press the button  briefly switch between single mileage (miles), total mileage (miles), max. speed (mph), and average speed (mph), when mileage reaches 9999.9km, the instrument is automatically reset to 0.0.

### 5.6 Drive mode selection

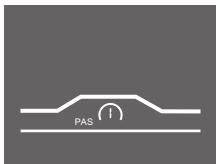

Press the button  for more than two seconds enter gear adjustment interface.

Press the button  /  briefly to switch between gear 1 and gear 2.

Press the button  briefly to save and exit.

#### **Info:**

Under the normal power on state, the instrument display 1 gear by default.

### 5.7 Error code display



When the vehicle electronic control system is fault, the instrument will automatically display the error code, the fault code is displayed in the mileage digital segment, the format is E0\*\*.

When there is an error code on the display interface, please troubleshoot the fault in time. After the fault occurs, the electric vehicle may not run normally.

### 5.8 Reset single mileage

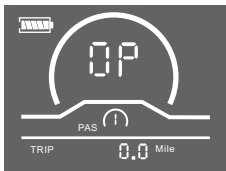

#### Condition:

The motorcycle is stationary.

Under power on state, the instrument display is "OP".

#### Operation:

Press the button  and  for more than 2 seconds, the instrument will be reset to 0.00.

### 5.9 Enter password setting

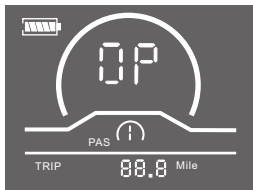





#### Condition:

- The motorcycle is stationary.
- Under power on state, the instrument display OP state.

#### Operation:

- Long press the button **+** and **-** until the instrument display “P0” state and.
- Briefly press the button **+** / **-** to select number, Briefly press the button **⏻** to confirm. if the input is completely correct, briefly press the button **⏻** to enter the setting interface.

if the input is completely error, briefly press the button  to switch to each position. briefly press the button  /  to reselect the number, briefly press the button  to confirm, after inputting, briefly press the button  to complete the setting.

### Info:

The instrument default password is 1313.

## 5.10 Setting kilometers or miles





### Condition:

– The motorcycle is stationary.

### Operation:

– Long press the button  and  until  appears at bottom left of the display.

- Enter the password, briefly press the button  to confirm.
- Briefly press the button  /  to switch between km/h and mph.
- “00” is as metric standard, “01” is as imperial standard.

### Info:

The instrument default is mph.

### 5.11 Power display

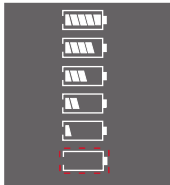

- The five-segment display of battery power. When the battery is full, the five-segment lights are all on. When the battery is under-voltage, the outer frame of the battery flashes, indicating that it needs to be charged immediately.

## 5.12 Fault code definition

| Fault code | Definition                            |
|------------|---------------------------------------|
| E002       | Communication failure                 |
| E080       | Motor sensor failure                  |
| E081       | Battery undervoltage                  |
| E082       | Battery overvoltage                   |
| E083       | The controller temperature too high   |
| E084       | Electronically controlled overcurrent |
| E085       | Throttle failure                      |
| E086       | The motor stalling                    |
| E087       | The motor temperature too high        |

# Basic Vehicle Operation

|            |  |             |
|------------|--|-------------|
| <b>6.1</b> | <b>Precautions for safe riding.....</b>  | <b>p.37</b> |
| <b>6.2</b> | <b>How to start your motorcycle.....</b> | <b>p.37</b> |
| <b>6.3</b> | <b>How to stop your motorcycle.....</b>  | <b>p.38</b> |
| <b>6.4</b> | <b>How to break.....</b>                 | <b>p.38</b> |
| <b>6.5</b> | <b>How to park.....</b>                  | <b>p.39</b> |
| <b>6.6</b> | <b>Post-ride inspection .....</b>        | <b>p.40</b> |
| <b>6.7</b> | <b>Maximum permissible loading.....</b>  | <b>p.40</b> |
| <b>6.8</b> | <b>Wading.....</b>                       | <b>p.42</b> |

This section gives basic information on how to start and stop your motorcycle , how to brake and park.

### **6.1 Precautions for safe riding**

Before riding your motorcycle for the first time, please review the Important Safety Information beginning on page 2.

Even if you have ridden other motorcycles, take time to become familiar with how this motorcycle works and handles. Practice in a safe area until you build up your skills and get accustomed to your motorcycle's size and weight.

Your motorcycle is not equipped with lights. Do not ride at night.

### **6.2 How to start your motorcycle**

Always follow the proper starting procedure described below.

1. Before starting, insert the key and turn the ignition switch “ON”.
2. Pressing the start button(p.23 ) , the vehicle is activated from standby to riding mode.
3. When you start riding, gently rotate the throttle.

### **Info:**

During this period, avoid full-throttle starts and rapid acceleration.

### **6.3 How to stop your motorcycle**

Gradually release the accelerator and when the vehicle comes to a complete stop, turn the ignition switch “OFF” and remove the key.

### **6.4 How to break**

To slow or stop, apply the front brake and rear brake pedal smoothly, Gradually increase braking as you feel the brakes slowing your speed. For support, put your left foot down first, then your right foot when you have finished using the rear brake.

Applying the brakes too hard may cause the wheels to lock and slide, reducing control of your motorcycle. If this happens, release the brake controls, steer straight ahead until you regain control, then reapply the brakes more gently.

Generally, reduce your speed or complete braking before beginning a turn. Avoid braking or closing the throttle quickly while turning.

When riding in wet or rainy conditions, or on loose surfaces, the ability to maneuver and stop will be reduced. All of your actions should be smooth under these conditions. Rapid acceleration, braking or turning may cause loss of control. For your safety, exercise extreme caution when braking, accelerating, or turning.

### 6.5 How to park

Lower the side stand to support your motorcycle. Turn the ignition switch “OFF” and remove the key. choose a level place to park.

### 6.6 Post-ride inspection

When you return home after riding, thoroughly clean your motorcycle and remove any dirt, mud, sand, rocks or other objects.

After cleaning, carefully inspect your motorcycle for leaks or damage.

Be sure to lubricate the drive chain to prevent rusting.

### 6.7 Maximum permissible loading

This vehicle was designed as a recreational motorcycle. It was not designed to carry a passenger or cargo. A passenger or cargo could interfere with your ability to move around to maintain your balance and control of the motorcycle.

In addition, exceeding the weight limits or carrying an unbalanced load can seriously affect your motorcycle's handling, braking, and stability. Adding accessories or making modifications that change this motorcycle's design and performance can also make it unsafe.

How much weight you put on your motorcycle, and how you load it, are important to your safety. If you decide to carry cargo, you should be aware of the following information.

**⚠ WARNING**

Overloading or carrying a passenger can cause a crash and you can be seriously hurt or killed.

**Following are the load limits for your motorcycle.**

Guideline:

|   |              |
|---|--------------|
| Maximum permissible loading                           | 99lbs (45kg) |
| Includes the weight of the rider and any accessories. |              |

**Info:**

we recommend that you do not carry any cargo on this motorcycle. However, if you decide to carry cargo, ride at reduced speeds and follow these common-sense guidelines:

1. Keep cargo small and light. Make sure it cannot easily be caught on brush or other objects, and that it does not interfere with your ability to shift position to maintain balance and stability.
2. Place weight as close to the center of the motorcycle as possible.
3. Make sure that all cargo is tied down securely.
4. Never exceed the maximum permissible weight.
5. Check that both tires are inflated properly.

### 6.8 Wading

#### **Info:**

If you are riding on a rainy day, please slow down, brake slowly, judge the road conditions as soon as possible, and do not brake suddenly to avoid the wheel slipping.

Do not wade easily when riding, and be careful not to pass through places where the water is too deep. Although the motor, battery, controller and other important parts of the motorcycle have been waterproofed, this does not mean walking in the water at will, especially don't rush into the place where water is accumulated, and drive in a detour. Don't let water flood the motor, so as not to cause the motor malfunction.

After riding, don't rush to charge the motorcycle. This may cause a short circuit. Motorcycles should be placed in a ventilated place to keep the rain dry. The key components of the battery and connection socket must be wiped dry to avoid accidents.

**Info:**

For the safety of your vehicle, the wading depth under normal driving is less than 100mm.

# Maintenance Schedule

|   |             |
|---|-------------|
| <b>7.1 Daily safety inspection.....</b> | <b>p.45</b> |
| <b>7.2 Regular maintenance .....</b>    | <b>p.47</b> |

### 7.1 Daily safety inspection

Check the following items before driving every day. Developing this habit can ensure your driving safety and the reliability of the vehicle. If you find any abnormality, please refer to the adjustment section or contact your dealer for repair. If you find anomalies continue to drive it will cause serious damage to the vehicle or an accident.

| Items       | Content   |
|-------------|---|
| Front wheel | Check the front wheel for excessive wear, incisions, inserted foreign objects, or other damage. Check that the front tire pressure is normal. |
| Front brake | Check the thickness of front brake pads. Check brake disc thickness and stain.  |
| Rear wheel  | Check the rear wheel for excessive wear, incisions, inserted foreign objects, or other damage. Check that the rear tire pressure is normal.   |

|                     |   |
|---------------------|---|
| Front brake         | Check the thickness of rear brake pads. Check brake disc thickness and stain.                   |
| Motor               | Check the appearance of the motor for breakage and gear oil leakage.                            |
| Brake oil           | Check front and rear brake fluid cups for proper level.   |
| Instrument          | Check instrument fault display. Check whether the power battery reserves are sufficient.        |
| Operating component | Check Weather the handlebar, front and rear brake, throttle and switch are normal and flexible. |
| Side stand          | Check whether the side stand return spring is loose or broken.                                  |
| Ignition switch     | Check whether the ignition switch can be used normally.   |

## 7.2 Regular maintenance

Regular maintenance schedule(I=Inspection, L= lubricate, C=Clean  
R=Replace)

| Items        | 200km   | 1000km  | 2000km   | 3000km   |
|--------------|---------|---------|----------|----------|
|              | 1 month | 6 month | 12 month | 18 month |
| Brake system | I       | I       | I        | I        |
| Wheels&Tires | I       | I       | I        | I        |
| Drive Chain  | I+C     | I+C     | I+C      | I+C      |
| Suspension   | I       | I       | I        | I        |
| Motor        | I       | I       | I        | I        |
| Battery      | I       | I       | I        | I        |

|                         |   |   |   |   |
|-------------------------|---|---|---|---|
| Side stand              |   | I |   | I |
| Motor oil               | R |   |   | R |
| Nuts, Bolts, Fasteners  | I |   | I |   |
| Steering Head Bearings  | I |   | I |   |
| Vehicle operation check | I | I | I | I |

### Info:

If you do not feel capable of performing a given task or need assistance, remember that your GREENGER dealer knows your motorcycle best and is fully equipped to maintain and repair it. If you decide to do your own maintenance, use only GREENGER Genuine Parts or their equivalents for repair or replacement to ensure the best quality and reliability.

# Service Your Vehicle

- 8.1 Removing the front shock absorber.....p.51**
- 8.2 Installing the front shock absorber.....p.52**
- 8.3 Removing the lower triple clamp.....p.53**
- 8.4 Installing the lower triple clamp.....p.55**
- 8.5 Removing the front cover.....p.58**
- 8.6 Installing the front cover .....p.58**
- 8.7 Removing front fender .....p.59**

|             |   |             |
|-------------|---|-------------|
| <b>8.8</b>  | <b>Installing front fender .....</b>            | <b>p.59</b> |
| <b>8.9</b>  | <b>Removing the rear shock absorber .....</b>   | <b>p.60</b> |
| <b>8.10</b> | <b>Installing the rear shock absorber .....</b> | <b>p.61</b> |
| <b>8.11</b> | <b>Removing the seat .....</b>                  | <b>p.62</b> |
| <b>8.12</b> | <b>Installing the seat .....</b>                | <b>p.62</b> |
| <b>8.13</b> | <b>Checking the drive chain tension .....</b>   | <b>p.63</b> |
| <b>8.14</b> | <b>Adjusting the drive chain tension.....</b>   | <b>p.64</b> |

Keeping your motorcycle well maintained is absolutely essential to your safety. It's also a good way to protect your investment, get maximum performance, avoid breakdowns, and have more fun.

### 8.1 Removing the front shock absorber

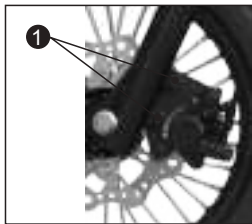

#### Specific steps:

1. Place the motorcycle on a maintenance stand.
2. Remove the front wheel.
3. Remove screws **1** and take off the brake caliper.

#### Notice :

Make sure that the brake caliper and brake cable are not entangled

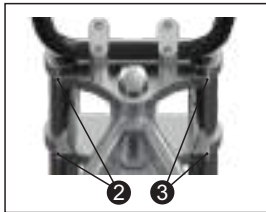

4. Loosen screws ② and remove the left shock absorber.

5. Loosen screws ③ and remove the right shock absorber.

### 8.2 Installing the front shock absorber

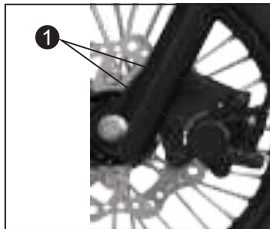

#### Specific steps:

1. Position the brake caliper, mount screw ① and tighten.

#### Reference torque:

|                            |    |                  |
|----------------------------|----|------------------|
| Screw, front brake caliper | M8 | 20Nm(14.8lbf.ft) |
|----------------------------|----|------------------|

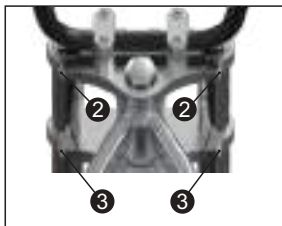

2. Tighten screw ②

**Reference torque:**

|                           |    |                  |
|---------------------------|----|------------------|
| Screw, upper triple clamp | M8 | 20Nm(14.8lbf.ft) |
|---------------------------|----|------------------|

3. Tighten screw ③

**Reference torque:**

|                           |    |                  |
|---------------------------|----|------------------|
| Screw, lower triple clamp | M8 | 15Nm(11.1lbf.ft) |
|---------------------------|----|------------------|

**Final work:**

4. Install the front wheel. 🛠️

### 8.3 Removing the lower triple clamp

**Specific steps:**

1. Place the motorcycle on a maintenance stand.

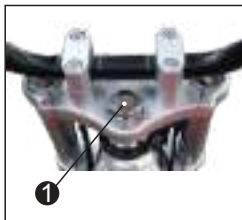

2. Remove the front wheel.
3. Remove the front shock absorber. (p.51)
4. Remove the front cover. (p.58)
5. Remove front fender. (p.59)
6. Remove nut ❶

---

### Notice:

Make sure that the brake cable are not entangled.

---



7. Remove locking nut ❷
8. Remove the lower triple clamp with the steering stem.
9. Remove the upper steering head bearing.

## 8.4 Installing the lower triple clamp

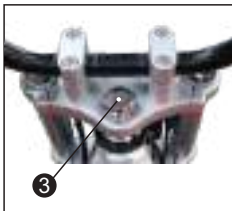
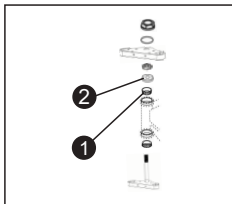

### Important work:

1. Clean the bearing , check for damage and grease.
2. Insert the lower triple clamp with the steering stem. Mount upper steering head bearing ① .
3. Push on protective ring ② .
4. Position the upper triple clamp with the handlebar.
5. Mount nut ③ , but do not tighten it yet.

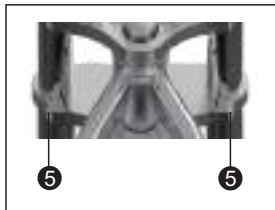

6. Tighten screws **5** .

**Reference torque:**

|                           |    |                   |
|---------------------------|----|-------------------|
| Screw, lower triple clamp | M8 | 15Nm (11.1lbf.ft) |
|---------------------------|----|-------------------|

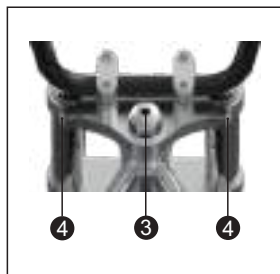

7. Tighten nut **3** .

**Reference torque:**

|                    |         |                  |
|--------------------|---------|------------------|
| Nut, steering head | M22×1.0 | 10Nm (7.4lbf.ft) |
|--------------------|---------|------------------|

8. Tighten nut **4** .

**Reference torque:**

|                           |    |                   |
|---------------------------|----|-------------------|
| Screw, upper triple clamp | M8 | 20Nm (14.8lbf.ft) |
|---------------------------|----|-------------------|

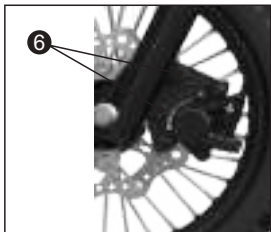

9. Position the brake caliper, mount bolt ⑥, and tighten.

**Reference torque:**

|                           |    |                   |
|---------------------------|----|-------------------|
| bolt, front brake caliper | M8 | 20Nm (14.8lbf.ft) |
|---------------------------|----|-------------------|

**Final work:**

1. Install front fender. (p.59)
2. Install the front cover. (p.58)
3. Check that brake line is routed correctly.
4. Install the front wheel.
5. Remove the motorcycle maintenance stand.

### 8.5 Removing the front cover



1. Remove screw ①.
2. Remove the front cover from the front fender.

### 8.6 Installing the front cover

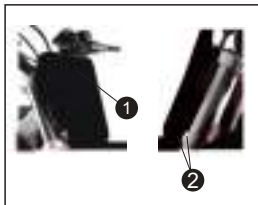

1. Position the front cover.
2. Holding lugs ② insert in the fender.
3. Mount and tighten screw ①.

#### Reference torque:

|                    |    |               |
|--------------------|----|---------------|
| Screw, front cover | M6 | 4Nm (31bf.ft) |
|--------------------|----|---------------|

## 8.7 Removing front fender

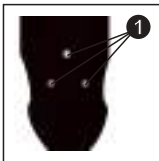

Remove screws ① , take off the front fender.

## 8.8 Installing front fender

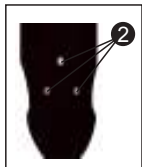

1. Insert the fender in the holding lugs ① .
2. Position front fender. Mount and tighten screws ② .

### Reference torque:

|               |    |                 |
|---------------|----|-----------------|
| Screw, fender | M6 | 6Nm (4.4lbf.ft) |
|---------------|----|-----------------|

### 8.9 Removing the rear shock absorber

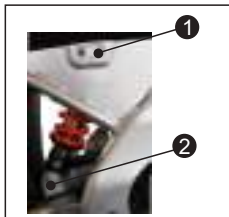

#### Specific steps:

1. Place the motorcycle on a maintenance stand.

#### Important work:

Note the mounting position of the rear shock absorber.

2. Remove screw ① and lower rear fork carefully.

3. Remove screws ② and remove the rear shock absorber.

## 8.10 Installing the rear shock absorber

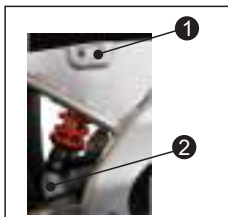

1. Install screw ① and tighten it. .

|       |     |                   |
|-------|-----|-------------------|
| Screw | M10 | 45Nm (33.2lbf.ft) |
|-------|-----|-------------------|

2. Install screw ② and tighten it.

|       |     |                   |
|-------|-----|-------------------|
| Screw | M10 | 45Nm (33.2lbf.ft) |
|-------|-----|-------------------|

### Final work:

Remove the motorcycle maintenance stand.

### 8.11 Removing the seat

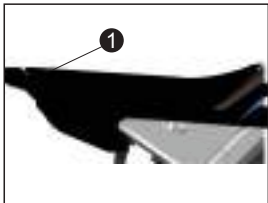

1. Remove screw ❶ and raise the rear of the seat.
2. Pull back the seat and remove it.

### 8.12 Installing the seat

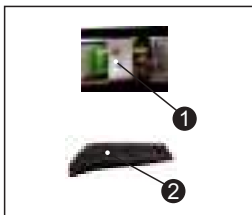

1. The seat holding lug ❷ hook onto holding lug ❶ , lower the seat , and push it forward.

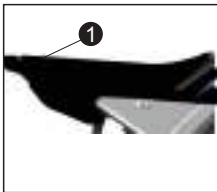

2. Mount screw ① .

## 8.13 Checking the drive chain tension

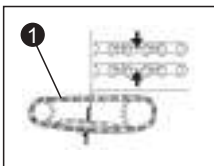

Check slack in the lower drive chain ① run midway between the sprockets. Drive chain slack should allow the following vertical movement by hand: (15-25mm)

### **Notice:**

If the chain tension is not satisfied specification. Need to adjust the chain tension progress.

### 8.14 Adjusting the drive chain tension

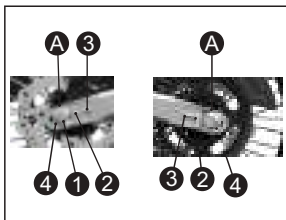

#### Specific steps:

Place the motorcycle on a maintenance stand.

#### Important work

1. Loosen the rear axle nut ①.
2. Loosen nut ②.
3. Adjust the chain tension by turning adjusting screws ③ left and right.

#### Reference:

|               |                             |
|---------------|-----------------------------|
| Chain tension | 15...25 mm (0.98...1.63 in) |
|---------------|-----------------------------|

4. Tighten nuts ②.
5. Make sure that chain adjusters ④ are fitted correctly on adjusting screw ③.
6. Tighten nut ①.

### Reference torque:

|                      |         |                   |
|----------------------|---------|-------------------|
| Nut, rear wheel axle | M14×1.5 | 40Nm (29.5lbs.ft) |
|----------------------|---------|-------------------|

### Final work:

Remove the motorcycle maintenance stand.

# Brake System

- 9.1 Adjusting brake lever freeplay .....p.67**
- 9.2 Checking front & rear brake discs .....p.68**
- 9.3 Checking front & rear brake caliper.....p.69**

## 9.1 Adjusting brake lever freeplay

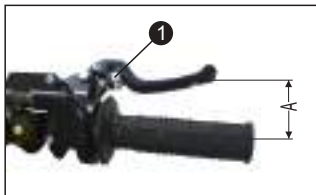

- Check the basic position of the hand brake lever.
- Adjust the basic position of the hand brake lever with adjusting screw **1** to rider's hand size.

### Info:

Turn the adjusting screw clockwise to increase the distance “A” between the hand brake lever and the handlebar.

Turn the adjusting screw counterclockwise to decrease the distance “A” between the hand brake lever and the handlebar.

The range of adjustment is limited.

### 9.2 Checking front & rear brake discs



Check the brake disc regularly to check whether the brake disc is damaged, deformed, cracked or Worn, damaged brake discs can cause brake failure, and worn brake discs can be reduced If the brake disc is damaged or exceeds the wear limit, contact GREENGER immediately the service center replaces the brake disc with a new one.

The thickness of the front and rear brake discs is detected at multiple locations of the discs.

**Brake disc wear limit: 3 mm.**

### 9.3 Checking front & rear brake caliper

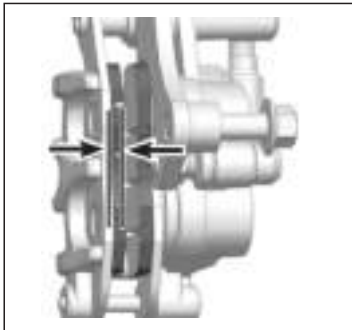

Check whether the brake caliper is abnormal before driving, and check the minimum thickness of the brake friction plate regularly. Too thin the friction pads will cause the brake pads bracket to rub the brake disc, which will seriously reduce the braking effect and damage the friction plate. Check the minimum thickness of brake pads on all brake calipers.

**Minimum brake pads thickness: 2 mm**

If the thickness of the brake pads are less than the minimum thickness, or the brake pads are damaged, please immediately replace the brake pads, the brake pads should be replaced in pairs

# Motor, Battery, Charger

|             |   |             |
|-------------|---|-------------|
| <b>10.1</b> | <b>view of the motor.....</b>                   | <b>p.72</b> |
| <b>10.2</b> | <b>Replay the gearbox oil .....</b>             | <b>p.72</b> |
| <b>10.3</b> | <b>view of the battery.....</b>                 | <b>p.73</b> |
| <b>10.4</b> | <b>Battery compartment and replacement.....</b> | <b>p.73</b> |
| <b>10.5</b> | <b>View of battery charger.....</b>             | <b>p.74</b> |
| <b>10.6</b> | <b>Charger parameter .....</b>                  | <b>p.75</b> |
| <b>10.7</b> | <b>Battery parameter.....</b>                   | <b>p.76</b> |

|             |  |             |
|-------------|--|-------------|
| <b>10.8</b> | <b>Charging the battery .....</b>  | <b>p.77</b> |
| <b>10.9</b> | <b>Check controller three-phase cable, power line<br/>installation screws.....</b> | <b>p.79</b> |

## 10.1 View of the motor



- ① Motor
- ② Motor cable
- ③ Oil fill hole and exhaust hole
- ④ Oil drain-hole

## 10.2 Replay the gearbox oil

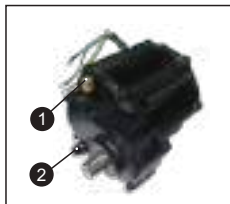

1. Remove screw ②, drain waste oil and tighten screw ②.
2. Remove screw ①, filling oil and tighten screw ①.

| Oil specification | Volume       |
|-------------------|--------------|
| GL-4, 85W / 90    | 40ml (1.4oz) |

### 10.3 View of the battery

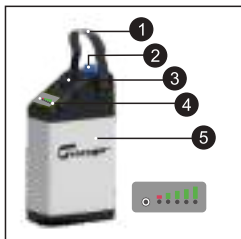

- ① Carrying handle
- ② Charging and discharging port
- ③ Pressure relief valve
- ④ Power display
- ⑤ Lithium battery

### 10.4 Battery compartment and replacement

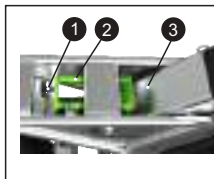

- ① The positioning screw
- ② The positioning bracket
- ③ The battery

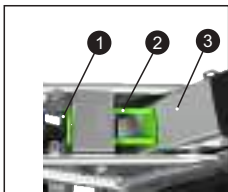

1. First put the battery **3** into the frame.
2. Push the battery bracket **2** forward to make it contact with the battery.
3. Tighten the position screw **1**.

---

### Info

Be careful not to tighten position screw **1** too tightly to avoid crushing battery outside case.

---

### 10.5 View of battery charger

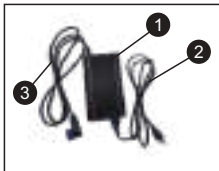

- 1** Battery charger
- 2** Charging cable
- 3** Power cord

**10.6 Charger parameter**

|                          |             |
|--------------------------|-------------|
| Input voltage            | 100~240V    |
| Input voltage frequency  | 50/60HZ     |
| Maximum charging voltage | DC54±0.2V   |
| Maximum input current    | 230V,AC2.5A |
| Output current           | 54V 5A      |

## 10.7 Battery parameter

|                       |   |
|-----------------------|---|
| Connection method     | 13S 4P  |
| Nominal voltage       | 48V   |
| Charging voltage      | 54.4±0.2V   |
| Standard charge       | 6A,54.6V  |
| Maximum charge        | 8A,54.6V  |
| Standard discharge    | 20A discharge, 39V cut off , at 25±3°C<br>( 103.6~114.4°F )       |
| Maximum discharge     | 35A(Continuous)   |
| Operating temperature | Charge: 0 ~ +55°C (32~131°F)<br>Discharge: -20 ~ +70°C (-4~158°F) |

## 10.8 Charging the battery

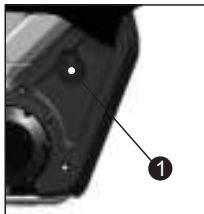

### Specific steps:

1. Remove charging socket protection cap ①.

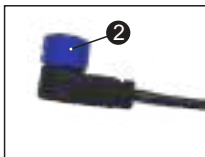

2. charging plug ② .

### Notice:

Make sure that all plug and cable are dry.

Only use the original battery charger to charge the battery.



3. Connect the battery charger to the battery.

### Guideline

|   |
|---|
| Observe plug marking <b>A</b>                 |
| Insert the plug straight in to avoid bending. |

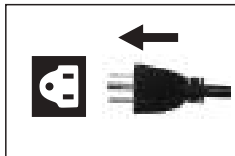

4. Connect the battery charger's power plug to the power supply.

The charger starts charging automatically

## 10.9 Check controller three-phase cable, power line installation screws

### **⚠ Warning**

Risk of safety If controller three-phase cable, power line installation screws is loosen, spark will be generated and there are safety risk.

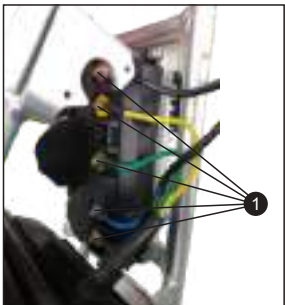

1. Park the vehicle on level surface.
2. Check controller three-phase cable, power line installation screws ① for looseness.  
» If controller three-phase cable, power line installation screws ① is loose.
3. Tighten screws ①.

|                     |    |                 |
|---------------------|----|-----------------|
| Installation screws | M4 | 5Nm (3.7lbf.ft) |
|---------------------|----|-----------------|

### **Info:**

Controller three-phase cable, power line should be checked every six months.

# Cleaning and Storage

|             |                                     |             |
|-------------|-------------------------------------|-------------|
| <b>11.1</b> | <b>Cleaning the motorcycle.....</b> | <b>p.81</b> |
| <b>11.2</b> | <b>Storage.....</b>                 | <b>p.82</b> |

## 11.1 Cleaning the motorcycle

**Material damage:** The vehicle and the battery are not suitable for high pressure cleaning.

The high pressure forces water into the electrical components, connectors throttle cables, and bearings, etc. As a result, components may be damaged or destroyed.

- Never clean the vehicle and battery with pressure cleaner or a powerful jet of water.
- Do not point a jet of water toward the battery discharge plug, even if the protection cap has been mounted.

### 11.2 Storage

If you plan to not ride or store the vehicle for an extended period (more than 30 days), it is recommended to charge the vehicle's power to over 60% and disconnect the charger.

During storage, the vehicle's self-discharge rate will be very slowly, but it is still necessary to check the battery level once a month. If the battery level is below 30%, please recharge it to over 60%.

To extend the life span of the vehicle's battery, store the vehicle in a cool place. Storing the vehicle in high-temperature areas will shorten the life span of the power unit.



Greenger Official Licensed Product.

Designed, manufactured and distributed by or for

Greenger Electronic Technology LLC. Greenger,  
the Wing logo, and livery are licensed by

American Greenger Motor Co., Inc.